



82350020  
77671

### INSTRUCTIONS

Jack vehicle, one end at a time, so tyres are 12cm (4-3/4") off floor. Position under tyres and centre them. Lower vehicle carefully into place. Repeat at other end of vehicle.

When moving vehicle, do so slowly and maintain control at all times. Observe load limit of 500kg each. Do not use on surface with slope, such as a driveway. Lubricate, frequently, both swivel bearings and axles.

### CAUTION!

Use exceptional care if engine is operational. If drive wheels are mistakenly engaged, the DOLLIES could be ejected, possibly causing damage or injury.

KEEP AWAY FROM CHILDREN!!  
THIS PRODUCT IS NOT A TOY!!

# 2 Pce Heavy Duty Wheel Dollies

### CASTOR ASSEMBLY

4 BOLTS EACH CASTOR  
TIGHTEN SECURELY

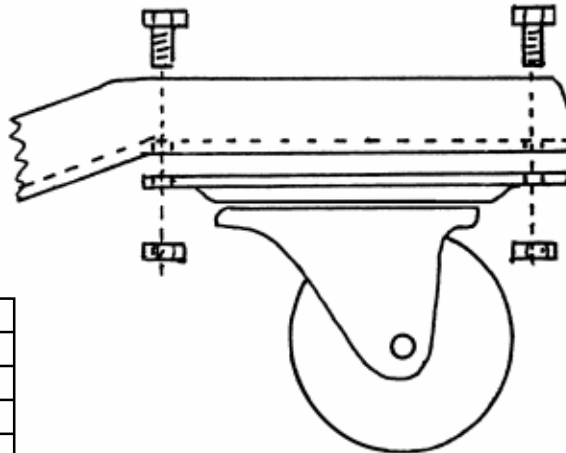

### PARTS LIST:

Part No.	Description	Qty
1	dolly	2
2	castor	8
3	ø5/16" x 5/8" bolt	32
4	ø5/16" nut	32
5	ø5/16" flat washer	32
6	ø5/16" lock washer	32

